

Summary

1	Instructions.....	34	11	Autosteamer.....	45
1.1	Read carefully	34	11.1	Description.....	45
1.2	How to use this manual.....	34	11.2	Autosteamer function	45
1.3	General warnings.....	34	12	Cup heater	46
1.4	Warranty.....	35	12.1	Models without display.....	46
1.5	Typographical conventions.....	35	12.2	Display version.....	46
2	Presentation	36	13	Washing the grouphead	47
3	Warnings for the installer	36	13.1	Version without display.....	47
3.1	Supply.....	36	13.2	Display version.....	47
3.2	Materials to be used.....	36	14	Programming	48
3.3	Hydraulic connections.....	36	14.1	Menu access.....	48
3.4	Activation.....	36	14.2	Counters.....	49
3.5	Maintenance and repairs.....	37	14.3	Boiler pressure	49
4	Description of the appliance	38	14.4	Cup warmer temperature	49
4.1	Description.....	38	14.5	Date and time adjustment	50
4.2	Push-button panel.....	39	14.6	Washing the groupheads	50
4.3	Autosteamer push-button panel.....	39	14.7	Information display.....	51
4.4	Indicator lights.....	39	14.8	Statistical data	51
4.5	Display touchscreen	40	15	Accessories.....	52
4.6	Technical data	40	15.1	Softener	52
5	Preparation.....	41	15.2	Cappuccino maker	53
6	Changing the water	41	15.3	Milk foaming nozzle.....	54
7	Starting the Machine	41	16	Suggestions on how to obtain a good cup of coffee....	54
7.1	Models without display.....	41	17	List of hazards.....	55
7.2	Models with display	41	18	Checks and cleaning	56
8	Preliminary operations	42	18.1	Checks and maintenance.....	56
8.1	Grinding and dosing.....	42	18.2	Cleaning.....	56
8.2	Preparing the filter holder.....	42	19	Malfunctions and related solutions	58
8.3	Lighting	42			
8.4	Cup trays	42			
9	Preparing the coffee	43			
9.1	Programming coffee dose	43			
9.2	Coffee delivery	43			
9.3	Viewing Information	43			
10	Preparing hot beverages.....	44			
10.1	Dispensing of hot water	44			
10.2	Dispensing steam.....	44			

1 Instructions

1.1 Read carefully

Carefully read every part of this booklet before using the appliance.

The espresso coffee maker that you have purchased has been designed and manufactured with innovative methods and technologies which ensure long lasting quality and reliability.

This booklet will guide you in discovering the advantages of purchasing our product. You will find information on how to get the best of your appliance, how to always keep it efficient and what to do if you should have any problems.

Keep this booklet in a safe place. If you lose it, you can ask the manufacturer for another copy.

We take this opportunity to send you our best regards.

ENJOY YOUR READING... AND YOUR COFFEE

1.2 How to use this manual

The manufacturer reserves the right to make any improvements and/or modifications to the product. We guarantee that this booklet reflects the technical state of the appliance at the time it is marketed.

We take this opportunity to invite customers to make any proposals for improving the product or the manual.

1.3 General warnings

- Installation must be done in accordance with the safety standards in force and by qualified and prepared personnel. Incorrect installation may be harmful to people, property or animals.
- This appliance is completely safe only if it is connected to an effective grounding system, carried out as required by current safety standards. The electric system must be equipped with a suitable differential circuit breaker. It is important to have these requirements checked. If in doubt, have the system carefully checked by qualified personnel. The manufacturer cannot be considered responsible for any damage caused by an inadequate electric system.
- Upon installation of the appliance, a main switch must be installed by qualified personnel, as required by current safety regulations, with an opening distance of the contacts equal to or greater than 3 mm.
- It is not advisable to use extensions or electrical adaptors with multiple outlets. If their use is indispensable, use only simple or multiple plug adaptors and extensions which are in accordance with the safety standards in force. Never exceed the power value in kW indicated on the simple adaptor and on the extensions and the maximum power value indicated on the adaptor.
- This appliance is to be used only for what it has been designed for. Any other use is considered improper and therefore dangerous. The manufacturer cannot be held responsible for any damage caused by an incorrect and unreasonable use.
- When using the electrical appliance several safety behavioural standards must be observed:
 - do not touch the appliance when hands or feet are wet or damp;
 - do not use the appliance in bare feet;
 - do not use extensions in showering or bathing premises;
 - do not pull on the power cord to unplug the appliance;
 - do not leave the appliance exposed to atmospheric agents (rain, sun, etc...) or in areas where water jets could be used;
 - do not allow the appliance to be used by children or incapable people;
 - do not access the inside of the machine;
 - do not spill liquid on the machine.
- After removing the packaging, check the condition of the appliance. If in doubt, do not use it but contact the retailer directly.
- The packaging material must not be left within the reach of children, since it is a potential source of danger. It is advisable to keep the packaging until after the warranty has expired.
- Before using the appliance, make sure that the mains voltage corresponds to the information on the data plate of the appliance.

- Make sure that the machine is used in a sufficiently lit, aerated, and hygienic premise.
- The access spaces to the machine and main switch must be left clear, in order to allow the user to intervene without any constrictions and be able to leave the area immediately in case of necessity.
- Do not spray water on the machine to clean it. Clean daily following the instructions given in this manual.
- Before any maintenance, disconnect the appliance from the electrical mains through the main switch.
- For daily cleaning, follow the instructions in this manual.
- In case of breakdowns or poor functioning, turn off the appliance, do not attempt any repairs; call for specialised technical service.
- Any repairs must be done only by the manufacturer or an authorised service centre, using original spare parts only. If this standard is not observed the safety of the appliance is compromised and cancels the guarantee.
- There is a lithium battery button inside the device to prevent programming data loss.
- The power cord of the device must not be replaced by the user. If the cord is damaged, turn off the machine and refer to technical or professionally qualified personnel.
- If you should decide not to use the appliance any longer, unplug it and have it drained of water by qualified personnel.
- To guarantee that the machine is efficient and works properly, it is essential to follow the manufacturer instructions, having periodical maintenance and a check of all the safety devices done by qualified personnel.
- Do not expose your hands or other body parts to the coffee, steam, or hot water spouts. The steam and water that come from the spouts can cause burns.
- When functioning, the filter holders, the steam and water spouts become overheated and are to be handled with caution only in the indicated parts.
- Cups must be placed on the special cup-heating surface only after having been thoroughly dried.
- The dishes belonging to the machine itself are to be placed on the cup-heater surface. It is incorrect to place any other object on this surface.
- The device can be used by children under 8 years old of age and by persons with reduced physical, sensory or mental capabilities, or lacking the experience or knowledge required, provided that they are under supervision, or receive instructions for the safe operation of the device and understand the dangers inherent in it.
- Children should not play with the device.
- Cleaning and maintenance should be carried out by the user, they must not be carried out by children without supervision.
- The coffee machine must be used at a temperature between 5°C and 40°C.
- Any unauthorised tampering with any parts of the machine renders any guarantee null and void.

1.4 Warranty

15 months on all components, except for electrical and electronic components and expendable pieces.

1.5 Typographical conventions



This symbol indicates that you must strictly follow the instructions it refers to, in order to avoid damage to the appliance or injury.



This symbol provides additional information on the operation of the appliance and its components.

2 Presentation

This product is manufactured in compliance with EU Directives, Regulations and Standards indicated in the EC Declaration of Conformity provided with the machine.

The espresso coffee maker is strictly for professional use only. It is designed for the preparation of hot drinks such as tea, cappuccinos, long, short and espresso coffee, etc.

The instructions for proper use of the machine are provided below.



The user must be sufficiently informed to operate the appliance correctly. It is recommended not to carry out any operations on the machine which may modify or alter its operation. WHEN THE MACHINE IS OPERATING, THE BOILER CONTAINS STEAM AND HOT WATER UNDER PRESSURE.



The machine's installation and maintenance operations can only be carried out by qualified technical personnel. Qualification can be provided by the builder through participation in specific training courses.



The installation and maintenance of the machine must be carried out only by qualified service personnel with knowledge and practical experience of the machine itself, with particular attention to the safety aspects and hygiene.

3 Warnings for the installer

3.1 Supply

The water supply of the appliance must be carried out with water which is suitable for human consumption, in compliance with the regulations in force in the place of installation. The owner / manager of the system must confirm to the installer that the water meets the requirements above.

3.2 Materials to be used

During the installation of the appliance, only the components and materials supplied with the appliance are to be used. Should the use of other components be necessary, the installer must verify their suitability to be used in contact with water used for human consumption.

3.3 Hydraulic connections

The installer must carry out the hydraulic connections in accordance with the hygiene norms and the hydraulic safety norms for environmental protection in force in the place of installation.

3.4 Activation

When installation is complete, the appliance has to be started, brought to the nominal working condition and left for 30 minutes in the "ready to operate" condition.

Afterwards, the appliance has to be turned off and emptied of the first water introduced in the whole hydraulic circuit, to eliminate possible initial impurities.

Then, the appliance must be once again loaded and brought to the nominal working conditions.

After reaching the "ready to operate" condition, the following has to be performed:

1. for each coffee unit, carry out a continuous delivery, in order to release the whole volume of water contained in each associated coffee tank;
2. release the entire volume of the hot water from the boiler by continuous delivery through the specific spout. In the case of several dispensing points, divide the volume on the base of the number of the dispensing points;
3. continuously release steam for at least 1 minute for each steam dispensing point.

3.5 Maintenance and repairs

After maintenance and/or repair intervention, the components used must ensure that the hygiene and safety requirements initially provided for the appliance are still met. These are met by using original spare parts only.

After repair or replacement of components related to parts in direct contact with water and food, a washing procedure has to be carried out, as in the case of first installation.



Maintenance operations should not be carried out by children without supervision.

4 Description of the appliance

4.1 Description

SAE Version

1. Machine power switch.
2. Hot water delivery nozzle.
3. Command facade.
4. Cup heater surface.
5. Warning lights.
6. Illuminated side.
7. Anti-burn seal.
8. Steam nozzle.
9. Adjustable foot.
10. Steam knob.
11. Folding cup warmer tray.
12. Filter holder.
13. Tray and cup support grille.
14. Pressure gauge.
15. Display.
16. USB socket.
17. Autosteamer push-button panel^(*).
18. Autosteamer nozzle^(*).
19. Sidelights switch.
20. Worktop light switch.



SAE Display Version

^(*) optional

picture A

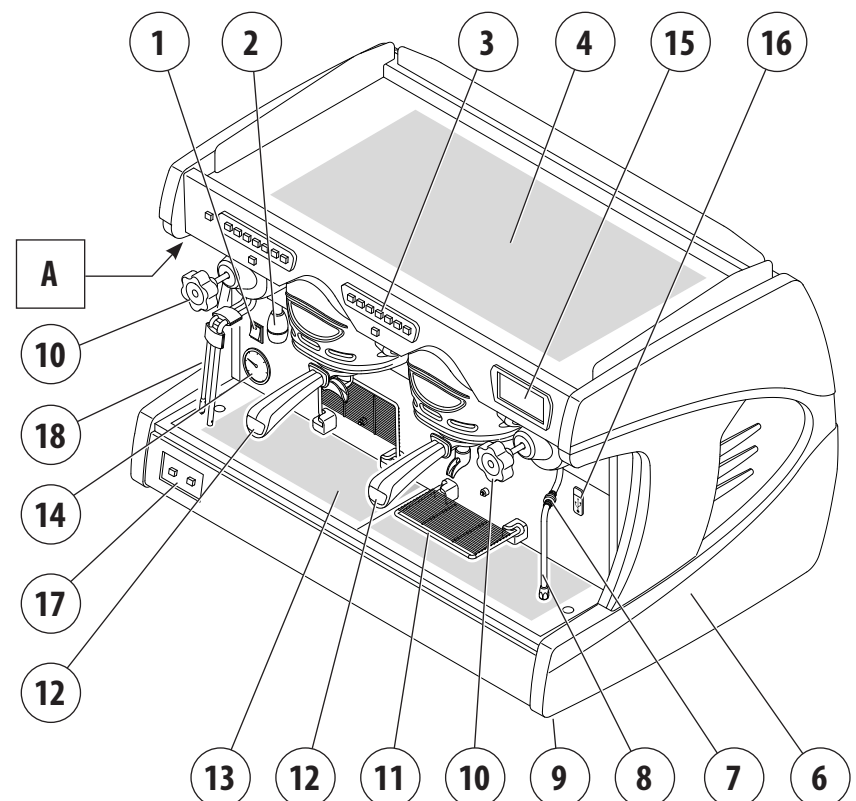
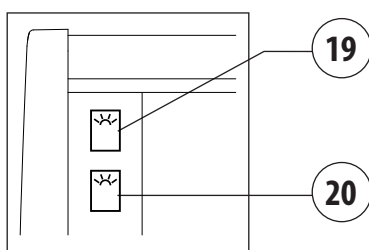

4.2 Push-button panel

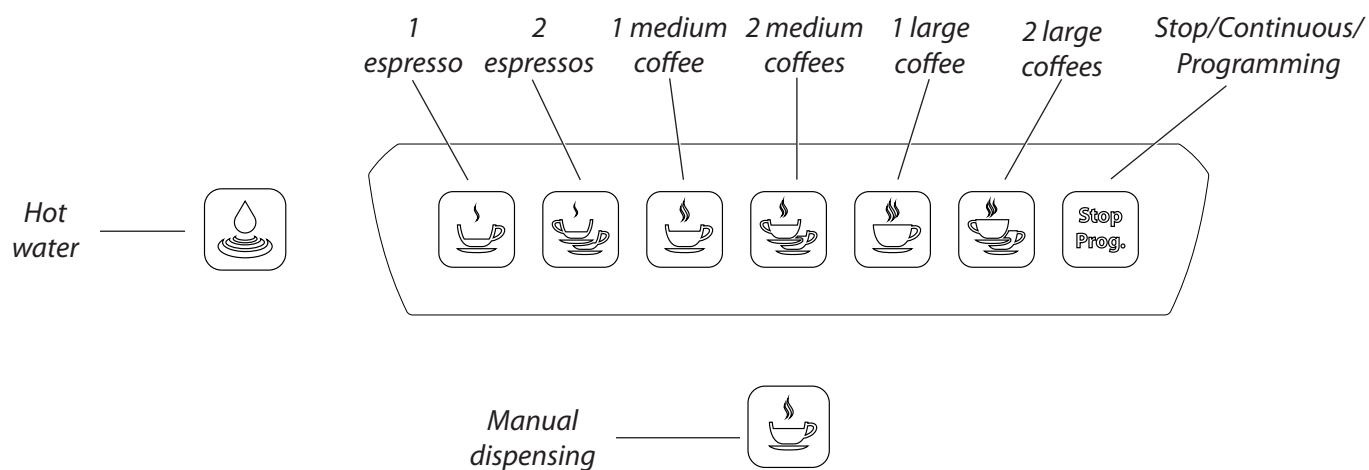

4.3 Autosteamer push-button panel

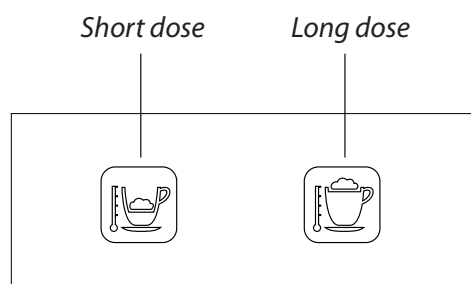

4.4 Indicator lights

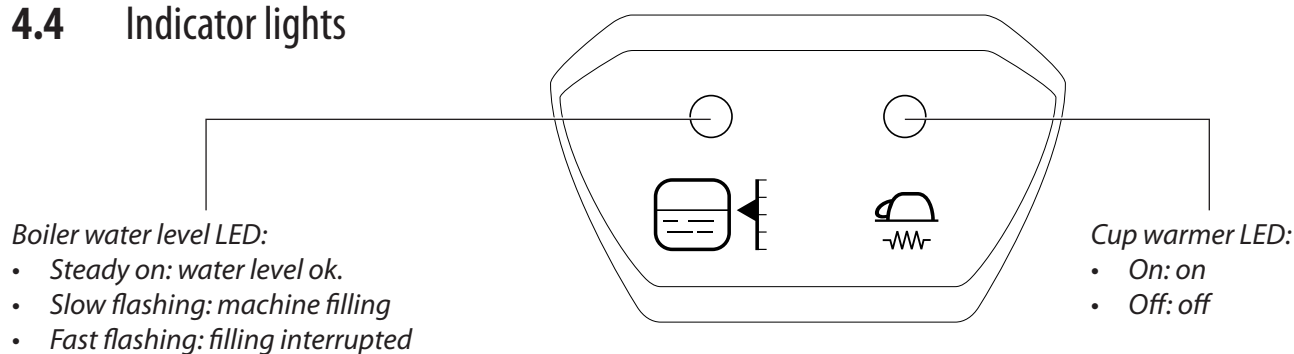

4.5 Display touchscreen

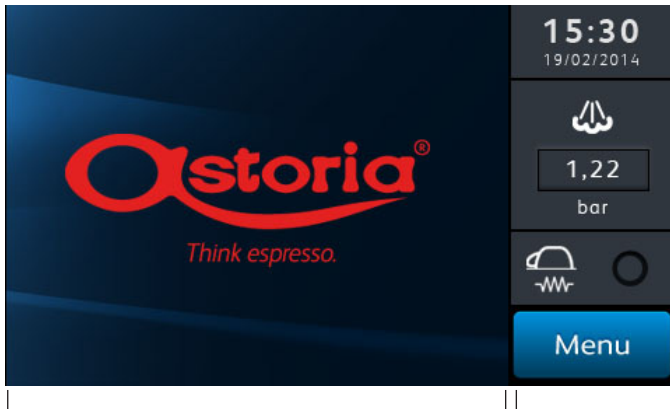

Time and date

Boiler pressure

Cup warmer indicator light

Menu button

Details and Menu access area

Information display area

Optional Functions

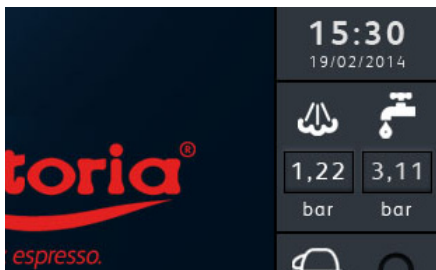

Water mains pressure

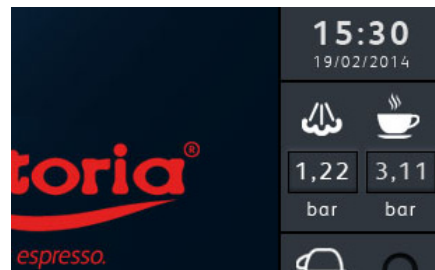

Hydraulic supply pressure

4.6 Technical data

The nameplate of the machine is fixed on the base of the frame under the drain pan.

The data of the appliance can be seen also on the label located on the package of the machine.

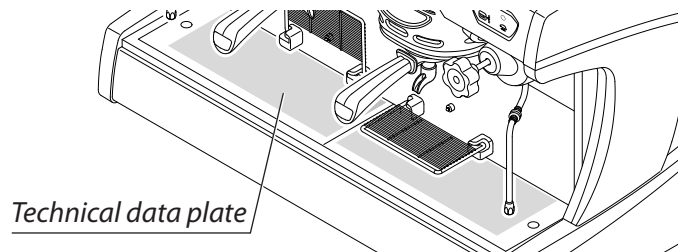

Technical data plate

		2GR			3GR		4GR	
		120	230-400 (2ph-3ph)	240	230-400 (2ph-3ph)	240	230-400 (2ph-3ph)	240
Power supply voltage	V	120	230-400 (2ph-3ph)	240	230-400 (2ph-3ph)	240	230-400 (2ph-3ph)	240
Absorbed power	W	3.100	3.900	4.200	5.600	6.000	6.600	7.100
Steam boiler capacity	L / gal UK	10,5 / 2,3			17 / 3,7		23 / 5,1	
Width	mm / in	835 / 32,9			1.075 / 42,3		1.315 / 51,8	
Depth	mm / in	574 / 22,6			574 / 22,6		574 / 22,6	
Height	mm / in	582 / 22,9			582 / 22,9		582 / 22,9	
Safety valve calibration	bar / psi	1,9 / 27,6						
Boiler operating pressure	bar / psi	0,8 ÷ 1,4 / 11,6 ÷ 20,3						
Feedwater pressure	bar / psi	1,5 ÷ 5 (MAX) / 21,8 ÷ 72,5 (MAX)						
Coffee dispensing pressure	bar / psi	8 ÷ 9 / 116 ÷ 130,5						
Net weight	kg / lb	72 / 159			88 / 194		109 / 240	
Gross weight	kg / lb	82 / 181			101 / 223		125 / 276	
Operating conditions	°C / °F	5 ÷ 40 / 41 ÷ 104						

5 Preparation

The preparation of the machine and the installation operations must be carried out by qualified personnel only.

The installer must strictly follow the indications provided in Chapter "Warnings for the Installer".

! Using the machine without all the installation operations having been carried out by technical personnel could damage it seriously.

! The machine must be placed in a perfectly horizontal position.

6 Changing the water

In case of breaks longer than 1 week, it is necessary to perform the changing of the 100% of the water contained in the hydraulic circuits of the machine, by using the appropriate dispensing points, as described in the Paragraph "Warnings for the Installer".

7 Starting the Machine

7.1 Models without display

Proceed as follows :

- Open the water tap of the water mains and of the softener;
- switch the main power switch to the ON position (1), the boiler water level indicator will begin flashing.
- wait for the boiler to automatically fill with water: the indicator stops flashing and remains on.

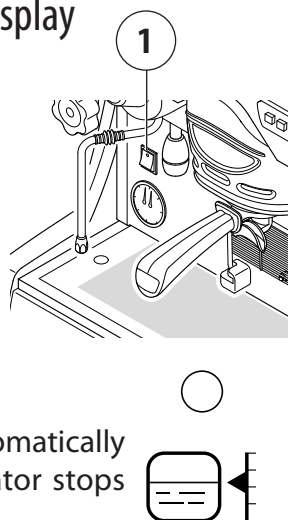

7.2 Models with display

- Open the water tap of the water mains and of the softener;
- press the main switch(1) of the machine;
- wait a few seconds longer for the auto-test to be carried out;
- wait for the boiler to automatically fill with water and for the machine to heat up;

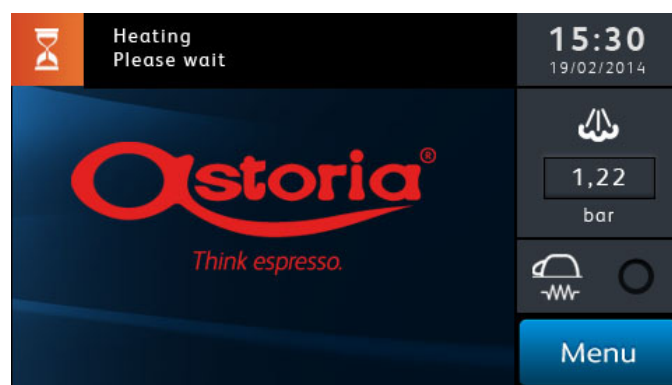

- the machine is ready for use when the following is shown on the the display:

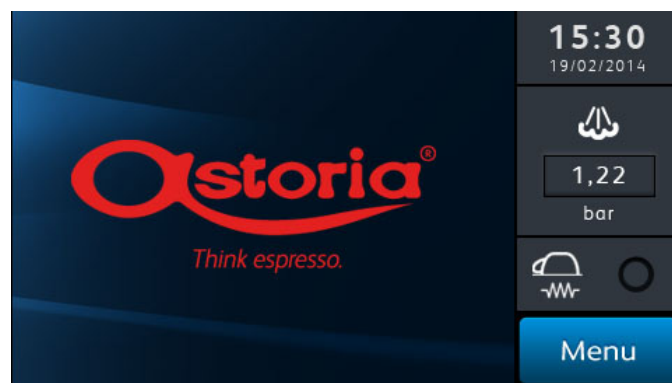

! To avoid the risk of burns, it is advisable to keep hands away from the hot water nozzle, steam nozzle and delivery groups during the machine's heating phase.

i During the machine's warm-up phase (roughly 20 minutes), the negative pressure valve will release steam for a few seconds until the valve itself closes.

i Before using the machine, run deliveries dry with the filter holder attached for a few seconds to release any air which may be in the circuit, so that the delivery groups are completely heated.

8 Preliminary operations

8.1 Grinding and dosing

It is important to have a dosing-grinding device next to the machine for the purpose of grinding the coffee used daily.

The grinding and the dosing of the coffee must be done according to that indicated by the manufacturer of the dosing-grinding device. The following points are also to be kept in mind:

- to obtain a good espresso it is recommended not to keep large stocks of coffee grains. Observe the expiry date indicated by the producer;
- never grind large volumes of coffee, it is advisable would be to have the quantity contained in the dosing device and use it if possible by the end of the day;
- if possible, never buy coffee that is already ground as it expires quickly. if necessary, to buy it in small vacuum-sealed packages.

8.2 Preparing the filter holder

- Fill the filter with a dose of ground coffee (circa 6-7 gr.) and press it with the press;
- hook the filter-holder to the unit without closing it too tightly in order to avoid excessive wear of the gasket;
- for the same reason it is recommended to clean the edge of the filter before attaching the filter holder to the dispensing unit;
- follow the procedures specified by the manufacturer of the grinder.

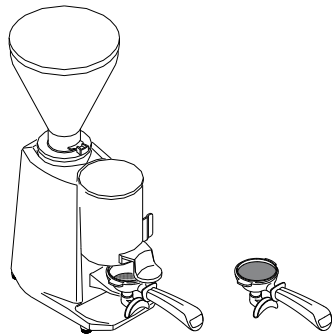

To prevent the seal from wearing too soon, clean the edge of the filter before engaging the filter holder on the delivery group. Do not excessively tighten the filter holder to the dispensing group.

8.3 Lighting

Brewing compartment

To turn the work area lighting on and off, press the switch (19) located on the front beneath the control panel on the left.

Sides

To turn the side lighting on and off, press the switch (20) located at the rear beneath the control panel on the left.

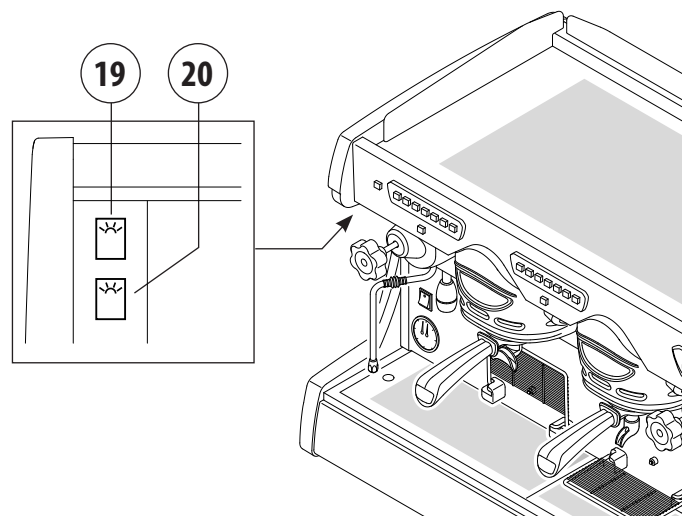

8.4 Cup trays

When different height cups are being used, there are special folding trays (11) on the machine to accommodate them.

To use a tray, unhook it and rotate it in a horizontal position.

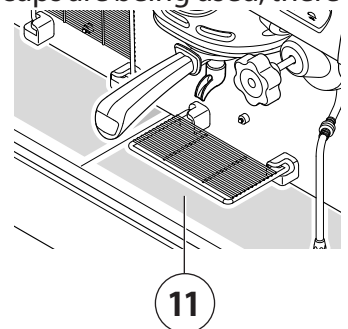

When no longer needed, push it upwards until it snaps back into its holder.

To clean the tray, see the "Cleaning" chapter.

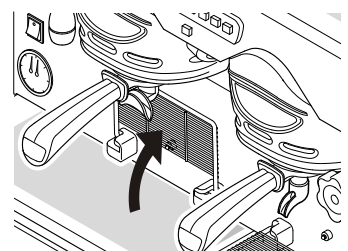

9 Preparing the coffee

9.1 Programming coffee dose

Always program the right push-button panel first, and, if necessary, the others subsequently.

- Place the coffee cup under the dispensing spout;
- press the **STOP/PROG.** button and keep it pressed for 5 seconds: lampeggio del led dello stesso tasto;
- press the dose key to be programmed (e.g. 1 espresso);
- wait for the brewing; to confirm the dose, press the dose button or the **STOP/PROG.** button again;
- repeat this operation for the other dose buttons;
- press the **STOP/PROG.** button to exit the programming mode.

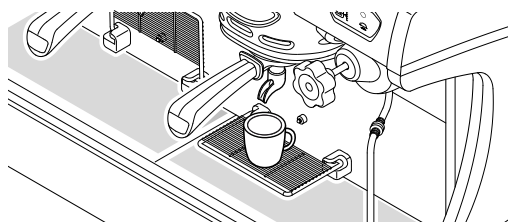

Successful programming of the dose is signalled by the LED of the corresponding button turning off.

Programming of each dose must be carried out with ground coffee and not with previously used grounds.

It is possible to program all machine's push-button panels simultaneously using only the left push-button panel. To obtain different doses for the various groups, perform the programming with the left push-button panel first, and then with all the others.

Do not remove the filter-holder from the delivery group during coffee delivery.

9.2 Coffee delivery

- Place the coffee cup under the dispensing spout;
- press the desired dose key and wait for coffee to be dispensed.

**To stop dispensing water ahead of time, press the STOP/ PROG button or press the button you selected again.
If the push-button panel is blocked, use the "Manual dispensing" button.**

9.3 Viewing Information

Depending on the configuration of the machine, certain information is shown on the display while the coffee is being brewed.

The hydraulic pressure during coffee brewing.



Diagram of the flow over time (ml/sec) of the coffee for a single group.

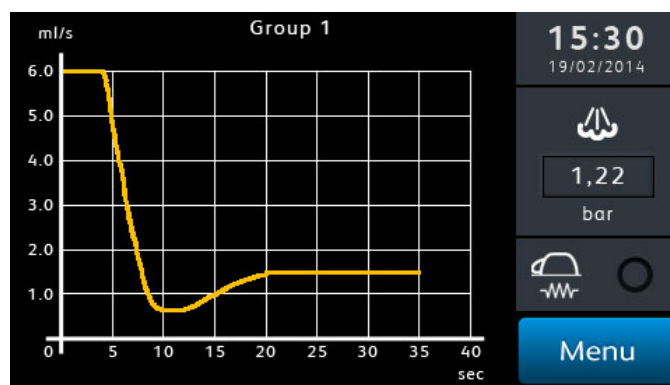

Display of the brewing time (sec) for all groups.

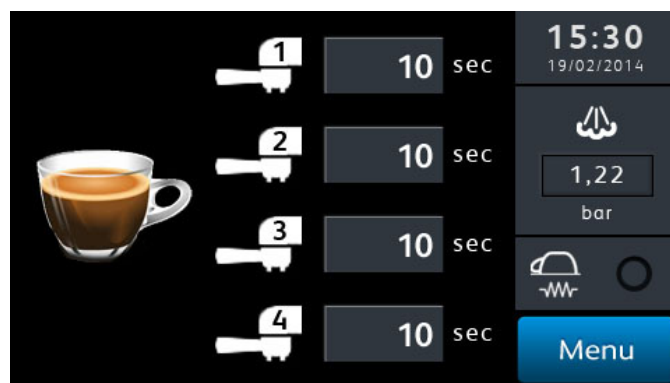

10 Preparing hot beverages

10.1 Dispensing of hot water

Programming

- Place the jug under the hot water nozzle (2);
- press the **STOP/PROG.** button on the right control panel for 5 seconds: the LED of the same button begins to flash;
- press the hot water button (☉);
- when the desired amount is delivered, confirm by again pressing the hot water button (☉);
- press the **STOP/PROG.** button to exit the programming mode.

Dispensing

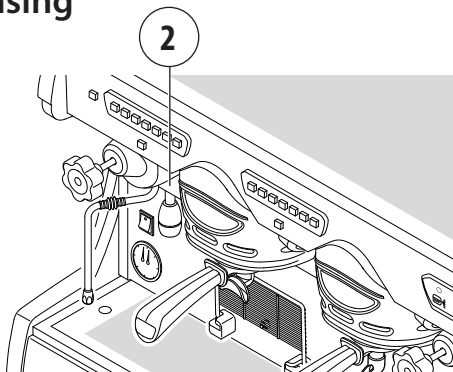

- Place the jug under the hot water nozzle(2);
- press the hot water button (☉): wait for the water to be dispensed.
- to stop delivery in advance, press the hot water delivery button (☉) again or press the **STOP/PROG.** button.



Carefully operate the steam nozzle using the anti-burn rubber bulb (7) and never touch the steam nozzle (8) or the hot water nozzle (2): contact with the hot water or steam may be harmful to individuals, animals or property.

10.2 Dispensing steam

Immerse the steam nozzle into the beverage to be heated and turn the tap knob (10) counterclockwise: the steam coming out of the nozzle (8) will be proportional to the opening of the tap.

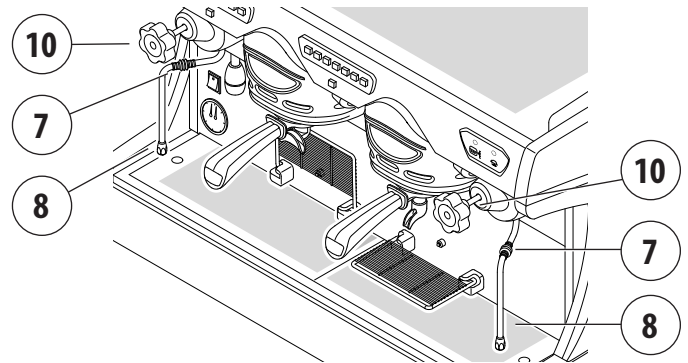

For optimal foaming, it is recommended to observe the following simple rules:

- heat only the amount of milk you intend to use, once heated, the milk will have to be completely poured from the jug and mustn't be heated again;
- the milk to be foamed must have a starting temperature of 4°C.



The use of the steam delivery point (steam nozzle), must always be preceded by condensation draining for at least 2 seconds.



Leave the steam nozzle immersed in the milk only for the heating time required.



Do not turn on the steam knob if the nozzle is in the milk and the machine is off.



To keep the steam nozzle tips in perfect working order, it is advisable to carry out a brief dry delivery after each use. Keep the tips clean at all times using a cloth dampened in lukewarm water. Handle the nozzle with utmost caution due to the hazard resulting from the presence of high-temperature steam.

11 Autosteamer

11.1 Description

The “Autosteamer” system can be used for automatically heating and foaming milk at the programmed temperature.

It can be controlled using the keypad (17) located on the left base of the machine.

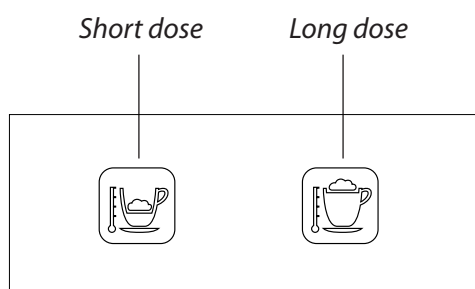
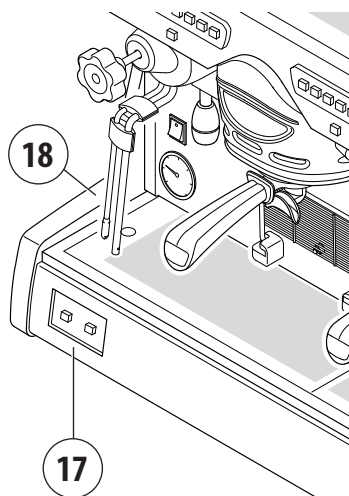

For optimal foaming, it is recommended to observe the following simple rules:

- heat only the amount of milk you intend to use, once heated, the milk will have to be completely poured from the jug and mustn't be heated again;
- the autosteamer guarantees a correspondence of $\pm 3^{\circ}\text{C}$ between the set temperature and the real temperature of the milk, only by starting from a milk temperature of 4°C ;
- since the dispensing of steam stops on its own when the set temperature of milk is reached, to prevent the milk foam from spilling out, it is necessary to introduce a volume of liquid not greater than 1/2 the capacity of the jug.
- use a container with a capacity of 0.75 litres and half-fill it with milk;

To change the temperature of the autosteamer, and to enable or disable its operation, contact the Technical Support Service.

11.2 Autosteamer function

Proceed as follows:

- Immerge the tips of the autosteamer (18) into the beverage;
- press the button (☕) or (☕) depending on the dose of milk in the jug;
- wait until the dispensing is finished;
- when the dispensing is finished, the milk will be foamed and heated at the preset temperature;
- to stop delivery in advance, press the same button again;
- by holding down the autosteamer button it is possible to extend steam dispensing beyond the set temperature.

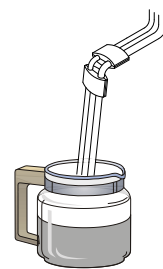

Refer to service assistance to regulate the foam of the milk.

The use of the steam delivery point (steam nozzle), must always be preceded by condensation draining for at least 2 seconds.

The system includes a 4-minute operation time-out for the Autosteamer device.

To keep the steam dispensers in perfect working order, it is advisable to carry out a brief dry delivery after each use. Keep the ends of the of the nozzle clean at all times by using a cloth dampened in lukewarm water. If regular cleaning is not carried out, the proper operation of the autosteamer can be jeopardized.

Do not leave the autosteamer nozzle immersed in the milk when it is not being used. Handle the autosteamer with the utmost caution due to the dangers resulting from the presence of high-temperature steam.

12 Cup heater

12.1 Models without display

Place the cups to be heated on the cup heater (4).

To adjust the cup heater, proceed as follows:

- Upon the switching on of the machine, keep the **STOP/PROG.** button on the right push-button panel pressed: the flashing will point out the present configuration of the cup heater according to what is indicated in the design shown alongside;
- hold down the **STOP/PROG.** button until the led on the keyboard changes from a flashing light to a fixed one;
- press the key that corresponds to the desired configuration;
- press **STOP/PROG.** button to confirm the operation.

The corresponding indicator light on the front buttons signals the status of the cup warmer.

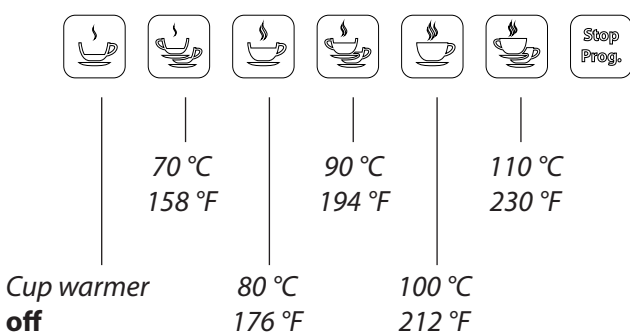
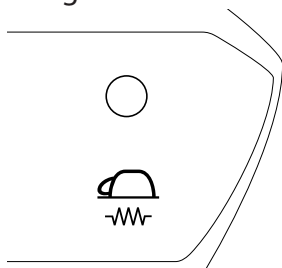

12.2 Display version

Place the cups to be heated on the cup heater (4).

To activate the cup warmer, press the button ().

The activation of the cup warmer is signalled on the display in the following ways.

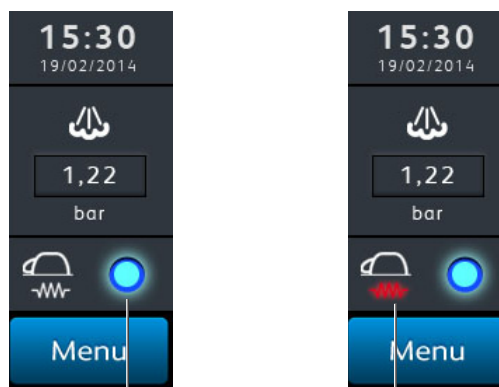

Cup warmer
on

Cup warmer on and
heating

i To adjust the temperature of the cup warmer, refer to the "Programming" section.

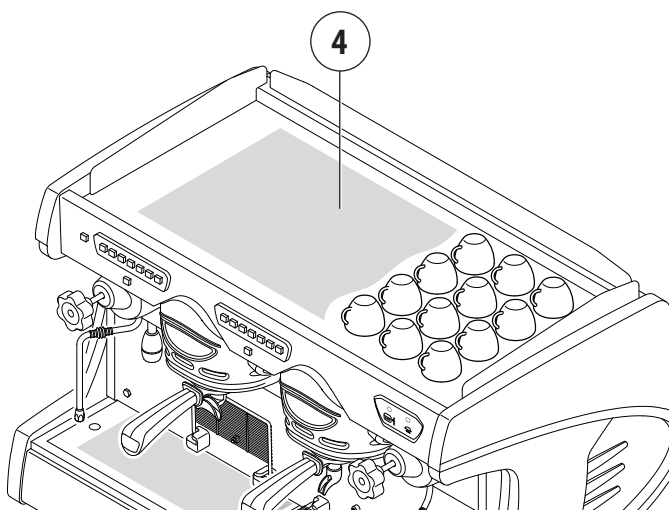









! For safety reasons it is advisable not to place cloths or other objects on the cup heater surface (4).

13 Washing the grouphead

13.1 Version without display

To activate the washing cycle, perform the following steps:

- press and hold for 10 seconds the double espresso button (2)  on the control panel relative to the grouphead to be cleaned, until the same button LED begins flashing;
- pour the detergent into the blind filter and attach the portafilter to the grouphead;
- press the double espresso button again (2) ;
- while the machine performs the first washing cycle, the leds of buttons  (1) and  (2) flash;
- once the first cycle finishes and only the led of the double espresso button  (2) is flashing, remove the portafilter from the grouphead;
- press the double espresso button  (2) again to proceed with rinsing;
- while the machine is rinsing, the leds of buttons  (1) and  (2) flash;
- once the rinsing cycle is complete (approximately 30 seconds), the machine is ready for normal use.

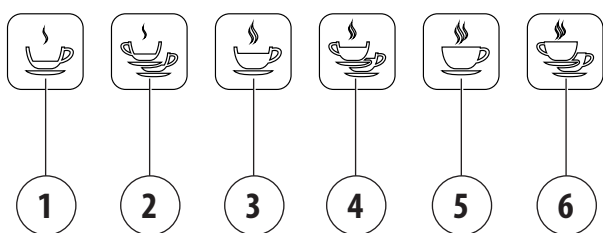

i The washing operations can be carried out simultaneously on several groupheads. To exit the washing phase, the washing must be completed on all the groupheads.

13.2 Display version

Press the  button to begin the wash cycle. Follow the steps indicated in the “Programming” section.



Washing the groupheads

i This procedure simultaneously washes all the groupheads; each keypad controls its corresponding grouphead.

14 Programming (display version only)

14.1 Menu access

To access the menu, press the button at the bottom right on the main page of the touchscreen display.

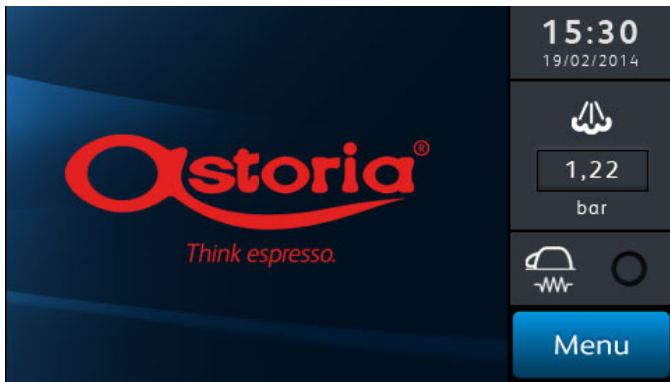

Menu button

Press the "Settings" button to access the appropriate sub-menu:

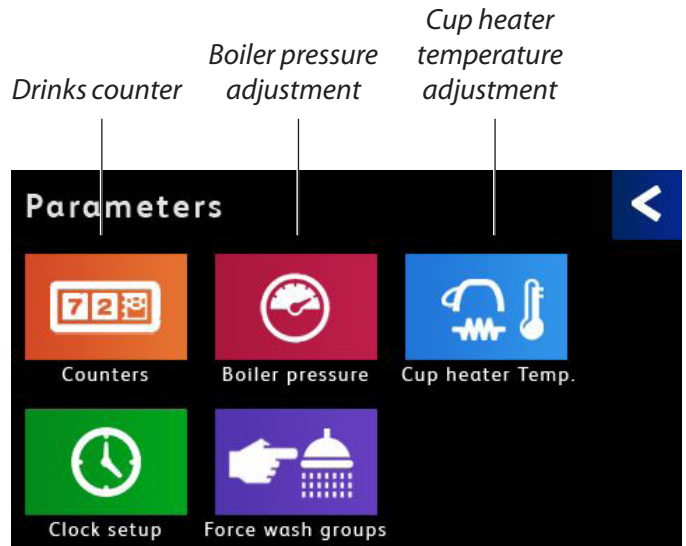

Drinks counter

Boiler pressure adjustment

Cup heater temperature adjustment

Date and time adjustment

Wash groupheads

The menu screen appears:

The "back" button returns to the previous screen

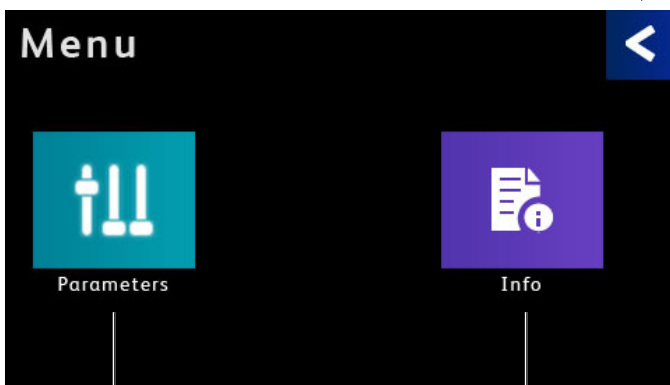

Settings button

Information button

Or press the "Information" button, to enter the information submenu:



Information

Statistical data

14.2 Counters



In this section, it is possible to display the number of selections made. By pressing the button, the screen below appears:

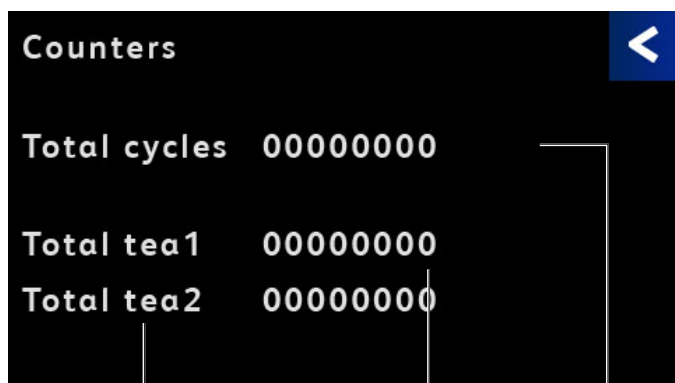

Total tea selections brewed by the right water nozzle (only 4GR)

Total coffees brewed

Total tea selections brewed (left water nozzle)

Press the back button [**<**] to return to the previous menu.

14.3 Boiler pressure



Allows the boiler pressure to be adjusted. By pressing the button, the screen below appears:

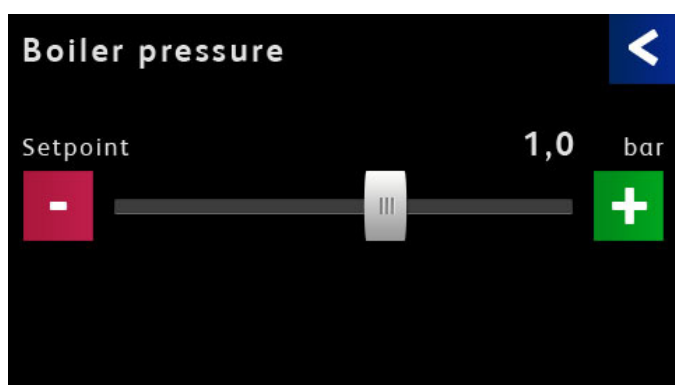

Use the slider or press the [**-**] and [**+**] buttons to set the desired pressure (measured in bar).

Press the back button [**<**] to return to the previous menu.

14.4 Cup warmer temperature



This menu allows adjustment of the operating temperature of the cup warmer, or to deactivate it completely. By pressing the button, the screen below appears:

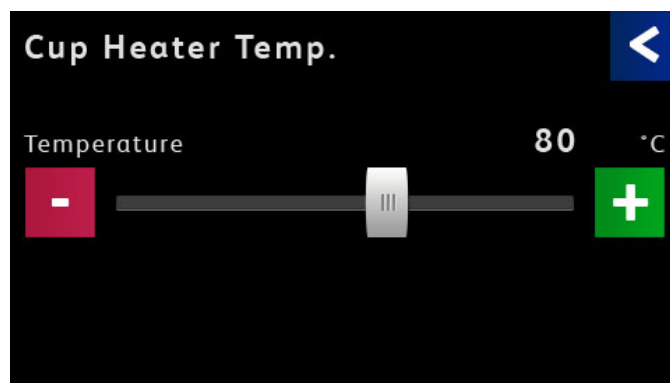

Use the slider or press the [**-**] and [**+**] buttons to set the desired temperature.

To turn the cup warmer off, move the slider completely to the left (the "---" value will appear).

Press the back button [**<**] to return to the previous menu.



When the cup warmer is on, the corresponding indicator on the display appears.

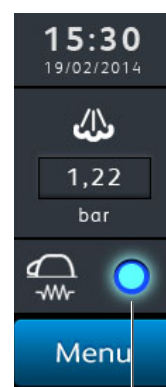

Cup warmer on

14.5 Date and time adjustment



In this section it is possible to set the date and hour shown on the machine's display. By pressing the button, the screen below appears:

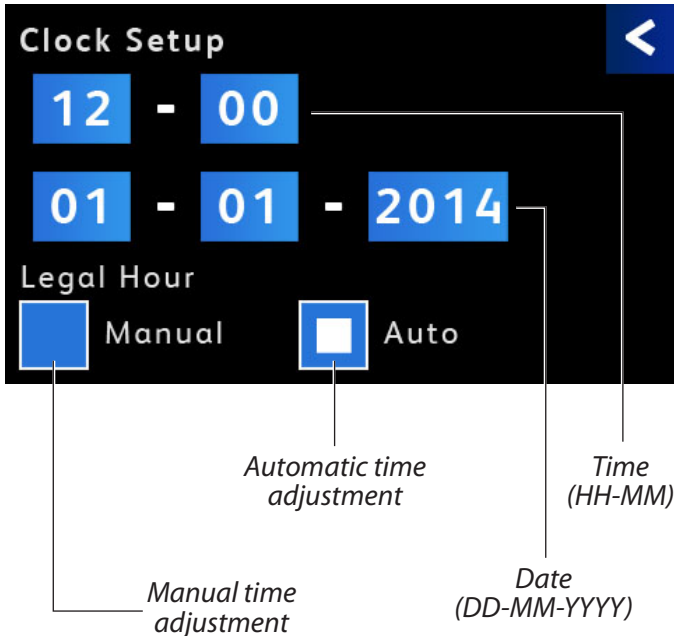

Press the field to be changed, then, in the new screen, use the slider or press the [-] and [+] to set the desired value.

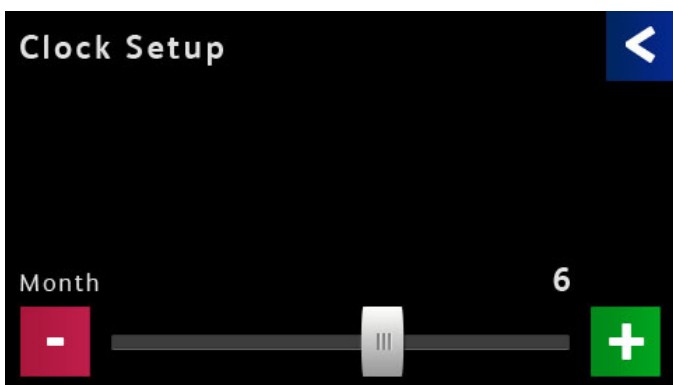

Example for setting the month.

To set the time manually or automatically, select the desired button.

Press the back button [<] to return to the previous menu.





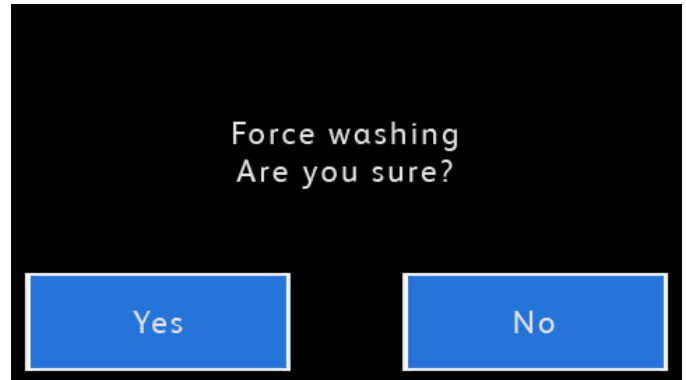

14.6 Washing the groupheads



This menu provides a wizard for washing the groupheads. By pressing the button, the screen below appears:



To start the washing cycle, press "YES" and proceed as follows:

- pour the detergent into the blind filters and attach the portafilters to the groupheads;
- press the double espresso button  (2) for each grouphead;
- the following message appears on the display: "Grouphead wash in progress." While the machine performs the first washing cycle, the leds of buttons  (1) and  (2) flash;
- the machine stops when the first cycle finishes and only the led of the double espresso buttons  (2) continues flashing; remove the portafilters from the groupheads;
- press the double espresso buttons again to proceed with rinsing  (2);
- while the machine is rinsing, the leds of buttons  (1) and  (2) flash;
- once the rinsing cycle is complete, the machine is ready for normal use

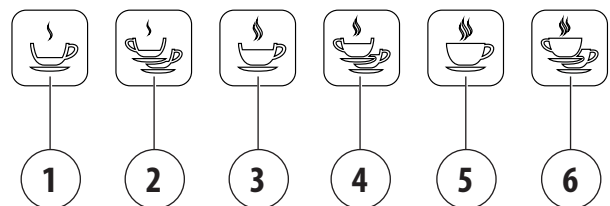

- **This procedure simultaneously washes all the groupheads; each keypad controls its corresponding grouphead.**

14.7 Information display



This menu allows you to view the current versions of the software installed on the machine. By pressing the button, the screen below appears:

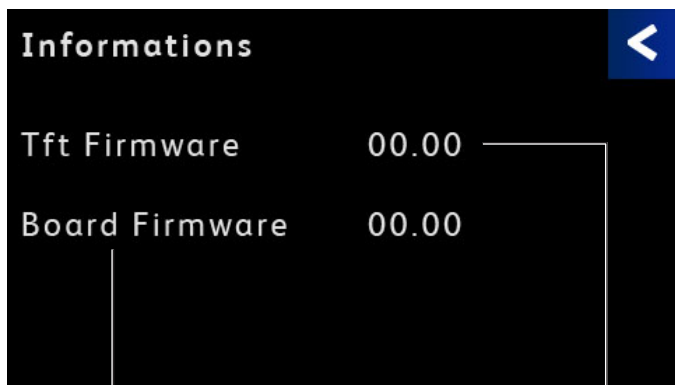

Firmware version of the CPU board

Firmware version of the LCD display

14.8 Statistical data



In this section, it is possible to display the number of coffees brewed. By pressing the button, the screen below appears.

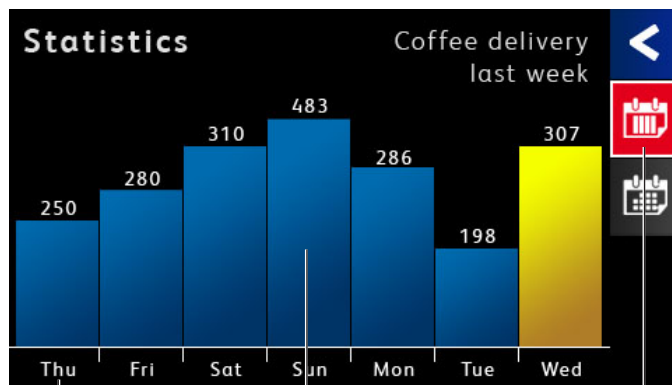

Days of the week

Weekly statistics

Daily number of brews

Depending on the button selected, weekly or monthly data can be viewed.

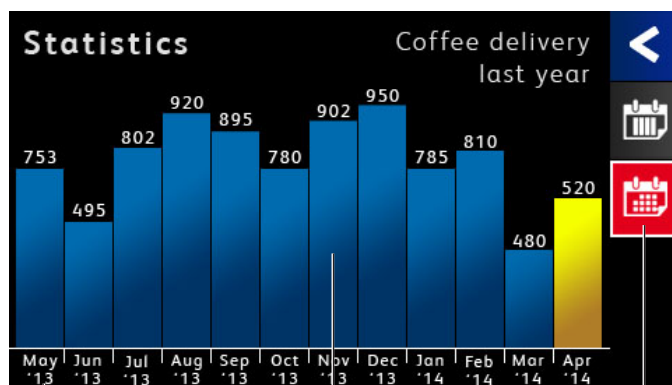

Months

Monthly statistics

Monthly number of brews

15 Accessories

15.1 Softener

Mains water contains insoluble salts, which cause the build-up of lime scale deposits in the boiler and other parts of the machine. The softener makes it possible to eliminate or substantially reduce the presence of these mineral salts. The resin softener has the property of retaining the calcium contained in the water. For this reason, the resins become saturated after a certain period and must be regenerated with coarse kitchen salt (NaCl, sodium chloride) or special water softening salt. It is very important to regenerate the softener within the established times. The regeneration is to be done regularly every 15 days. However, in locations where water is very hard, it will be necessary to regenerate it more frequently. The same rule can be applied to locations where there is a large consumption of hot water for tea or other uses.

Softener regeneration

Proceed as follows:

- move levers (B) and (E) from left to right;
- remove the lid by loosening the knob (A);
- release enough water through the pipe (C) to make room for the salt to be added, based on the model (see the table on the following page);
- clean any salt or resin residues from the gasket located on the cover;
- put the cover back in place by screwing the knob (A) down securely and move the lever (B) back from right to left;
- let the salt water drain from the little hose (D) until the water is no longer salty (about 30-60 minutes). The salt allows the accumulated mineral salts to be released;
- switch the lever (E) from right to left back to its initial position.

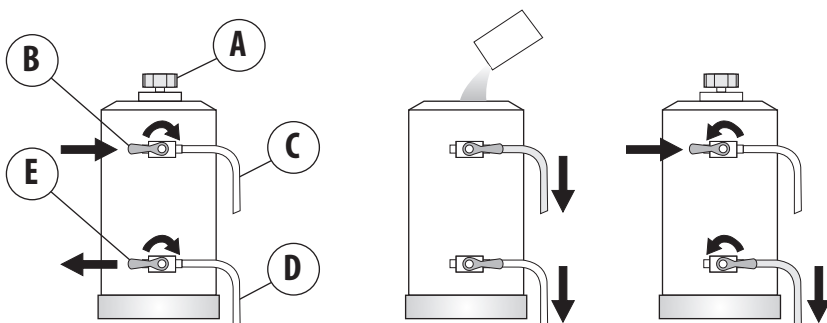

! The build-up of lime scale deposits in the hydraulic circuit and boiler inhibits thermal exchange, thus compromising proper operation of the machine. Heavy incrustations in the boiler may cause long machine shutdowns and in any case invalidate any guarantee, because this symptom indicates that regeneration has been neglected.

In order to keep the softener, and hence the machine, in perfect operating condition, it is necessary to regenerate it regularly, based on use of the softener and hardness of the water used. The table below shows the quantity of softened water based on the hardness of the water in the various units of measure:

°f: French degree

°d: German degree = 1.8 °f

mg CaCO₃

For further information on softener installation, start-up and regeneration, refer to the instruction manual.

Amount of softened water based on hardness

°f	30	40	60	80	salt
°d	16,5	22	33	44	
mg CaCO ₃	30	40	60	80	
8 liters	1000 lt	900 lt	700 lt	500 lt	1,0 kg
12 liters	1500 lt	1350 lt	1050 lt	750 lt	1,5 kg
16 liters	2100 lt	1800 lt	1400 lt	1000 lt	2,0 kg

Softener model	Amount of salt
8 liters	1.0 kg
12 liters	1.5 kg
16 liters	2.0 kg

Regeneration notification

If the function has been enabled during the programming phase, the machine calculates the water used and, if the threshold amount is exceeded, the display signals the need for regeneration.

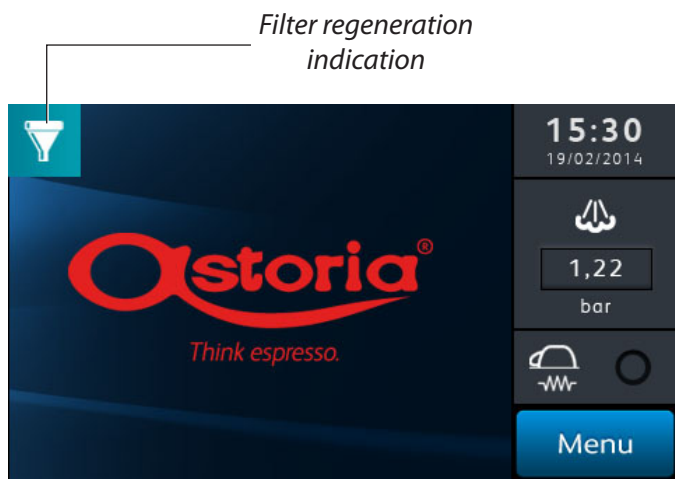

15.2 Cappuccino maker

- Put the suction tube inside the milk;
- place the jug under the spout of the cappuccino maker;
- turn the steam tap counter-clockwise, upon reaching the desired amount, close the steam tap;
- pour the latte into the cups with the coffee.

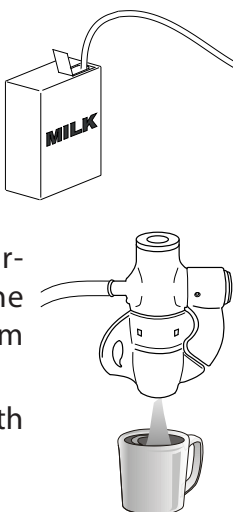

To obtain delivery of warm milk without foam, lift the tab (Z) upwards. For better results, we suggest not to dispense directly into the coffee cup, but into a jug or pot, and to then pour the foamed milk on the coffee. Be sure the cappuccino maker is kept clean as described in the chapter "Cleaning".

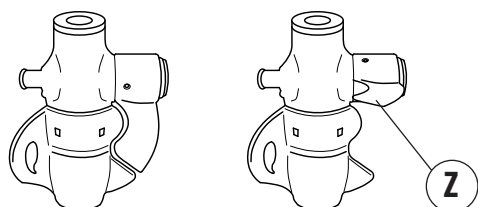

Cleaning

Use special care in cleaning the cappuccino maker, following the procedures indicated below:

- perform a first washing by immersing the suction tube in water and run a delivery for a few seconds;
- turn the rotating body (X) 90° to position B (closure of milk outlet duct);
- holding the milk suction tube in the air, dispense steam (cappuccino maker dry run);
- wait about 20 seconds to allow for internal cleaning and sterilisation of the cappuccino maker;
- close the steam and put the rotating body back in position A;
- if the air intake hole (Y) is blocked, clear it gently with a pin.

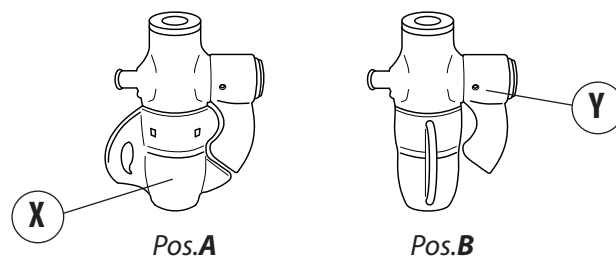

It is advisable to clean the cappuccino maker after each period of continued use so as to avoid malfunctions and to ensure a high rate of hygiene in the system.

15.3 Milk foaming nozzle

- Insert the nozzle **(A)** in the milk so that the sprayer is completely covered;
- turn the steam tap **(10)** counter-clockwise;
- wait for the milk to heat and foam;
- upon reaching the desired temperature and foaming, turn the steam tap **(10)** clockwise;

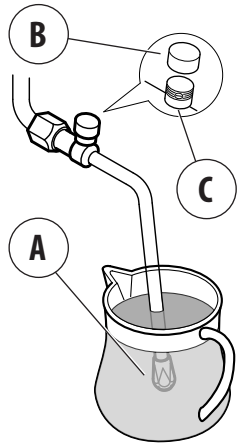
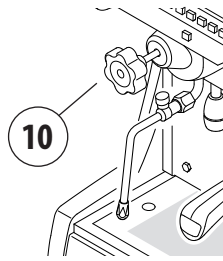

To adjust milk foaming proceed as follows:

- Use a wrench to unscrew component **(B)** of the milk foaming nozzle;
- Use a screwdriver on the screw **(C)** located inside the part:
 - to reduce foaming turn clockwise
 - to increase foaming turn counter-clockwise.

To keep the milk foaming device in perfect working order, it is advisable to carry out a delivery dry run after each use.

Keep the ends of the of the nozzle clean at all times by means of a cloth dampened in lukewarm water. Use the utmost caution with the milk foaming nozzle, as high-temperature steam is present.

16 Suggestions on how to obtain a good cup of coffee

To obtain high-quality coffee, it is important for the hardness of the water used to not exceed 4-5°f (French degrees). If the water hardness exceeds these values, it is advisable to use a water softener.

Avoid using a water softener if the water hardness is less than 4 °f.

If the taste of chlorine in the water is particularly strong, a special filter should be installed.

It is not advisable to keep large supplies of coffee beans. Never grind large amounts of coffee. Use the amount the doser holds and, if possible, use it by the end of the day. Never purchase ground coffee, as it expires quickly.

After the machine has not been used for a certain period of time (2-3 hours) carry out a few dry runs.

Make sure to carry out regular cleaning and maintenance.

Once the filter holder has been attached to the group, dispense as soon as possible.

If the type of coffee is changed, we recommended you to contact the Technical Support Service for the water temperature adjustment.

Adjust the grinding of the coffee according to the degree of humidity in the environment.

17 List of hazards

This chapter describes possible hazards for the user if the specific safety standards (described in this manual) are not followed.

The appliance must be connected to an efficient grounding system

If this is not done, the appliance can be a source of dangerous electrical shocks as it is no longer able to discharge electricity to earth.

Do not use running water for washing

The use of pressurized water directly on the machine can seriously damage the electrical equipment. Never use water jets to wash any part of the appliance.

Do not touch the dispenser unit

The high temperature of the dispenser unit may cause burns. Avoid contact of the dispenser unit with the hands or other parts of the body.

Be careful of the steam and hot water nozzles

During use, the steam and hot water nozzles become very hot and are thus a potential source of danger.

Handle these parts carefully. Never direct steam or hot water jets directly on the body.

Do not work on the machine when it is supplied with electrical power

Before carrying out any maintenance or repair work on the machine you must turn it off using the main switch or, better yet, disconnecting the mains connection terminals. Never remove any body panel when the machine is supplied with electrical power.

If you should decide not to use the appliance,

it is necessary to shut it down by disconnecting the power supply cable from the electrical mains, closing the inflow of water from the hydraulic mains and emptying the hydraulic system.

For the operations of disconnection from the electrical and hydraulic mains and of release of the water, qualified personnel has to be contacted.

Never work on the hydraulic system before having emptied it

All work regarding the hydraulic system and the related boiler is to be avoided when there is still water and pressure in the system. Thus you must empty it beforehand by closing the mains tap and dry-running the delivery group for a short time.

Switch off the machine and turn on all the steam and water taps. When the pressure is zero, empty the boiler completely by unscrewing the special pipe fitting located on the lower part of boiler.

If the above procedure is not carried out correctly, opening any part of the hydraulic system can cause a sudden outburst of superheated water under pressure.

Non-observance of the above-described standards can cause serious harm to people, property or animals.

Never operate the electronic apparatus when the appliance is supplied with electrical power.

Shut down the appliance completely by disconnecting it from the power outlet before carrying out any operation.

18 Checks and cleaning

18.1 Checks and maintenance

To ensure perfect safety and efficiency of the machine over time, it is necessary to carry out maintenance. In particular, **it is advisable to ask the Technical Service to carry out an overall check of the machine at least once a year.**

Checks	Daily	Weekly
MACHINE <ul style="list-style-type: none"> Using the machine display, check that the indicated pump pressure is around 8-9 bar. Check that the boiler pressure indicated on the display is consistent with a programming value. In case of anomalies, contact the Technical Support Service. 	X	
FILTER HOLDER FILTERS <ul style="list-style-type: none"> Check the wear of the filters, if there is damage to the edges, and if coffee grounds are getting into the cup. If necessary, replace the filters. 		X
GRINDER-DOSER <ul style="list-style-type: none"> Check the dose of the ground coffee, which should be about 6-7 gr. at a time, and adjust the amount as necessary. Check the degree of grinding and modify as required. Check the grinders for wear: they should be replaced if there is too much powder in the ground coffee. 		X
SOFTENER <ul style="list-style-type: none"> Carry out regeneration of the softener (for the manual softener). Check that there is salt in the container (for the softener in the automatic version). 		X

All maintenance operations must be carried out after unplugging the machine from the power supply, closing the water and completely cooling off the machine.

We recommend the use of suitable protective gloves.

If the problem cannot be resolved, turn the machine off and contact Technical Service. Do not attempt any sort of repairs. The descaling of the machine must be carried out by professional technicians to ensure that such operation does not lead to release of hazardous materials for food use.

18.2 Cleaning

For perfect cleaning and efficiency of the appliance, several simple cleaning operations are necessary on the functional parts and accessories as well as the body panels. The indications given here are applicable for normal use of the coffee machine. If the machine is used continuously, then cleaning should be performed more frequently.

Before cleaning the machine, turn it off the machine and let it cool off.

When cleaning, always use cloths that are completely clean and hygienic. To guarantee the correct operation and hygiene of the machine, it is necessary to use cleaning methods and products suitable for the purpose. Do not immerge the machine into water. Never use alkaline detergents, solvents, alcohol or aggressive substances. The descaling of the machine has to be performed by specialized technicians, by disassembling the components with deposits, so that no descaling debris is put into circulation. The used products/detergents have to be suitable for this purpose and must not corrode the materials of the hydraulic circuits

Cleaning operations should not be carried out by children without supervision.

Do not spill any liquids or use direct water jets on the machine.

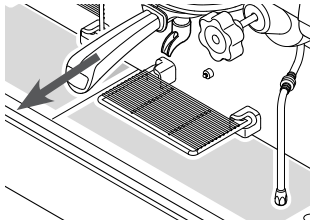
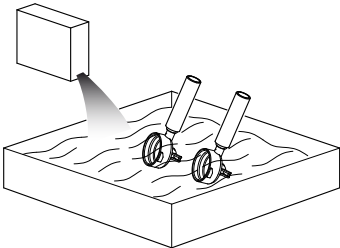
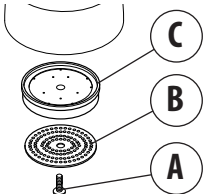
Cleaning	Daily	Weekly	Monthly	Pulizia	Daily.	Weekly.	Monthly
<p>CAPPUCCINO MAKER Clean several times a day as indicated in Paragraph "Cappuccino", especially if used continuously.</p>	XXX			<p>CUP TRAYS Disconnect the trays from their housing by positioning them horizontally and pulling them outwards. Clean with a cloth dampened in lukewarm water. Reinsert the trays in their housing.</p> 	X		
<p>FILTERS and FILTER HOLDERS Clean the filter holders daily by leaving them immersed in hot water all night so as to allow greasy coffee deposits to dissolve; afterwards, rinse off everything with cold water. Perform the same cleaning weekly for 10 minutes in hot water and the appropriate cleaner. Failure to clean the filter holders daily will jeopardize the quality of the coffee and the proper functioning of the filter holder. Warning: only immerse the cup of the filter holder. Avoid immersing the handle in water.</p> 	X			<p>STEAM NOZZLE - MILK FOAMER - AUTOSTEAMER Check and clean the terminals of the steam nozzles, using a small needle to reopen the exit holes. Clean the inside of the nozzle at least once a week:</p> <ul style="list-style-type: none"> dip the nozzle into a jug of water mixed with a specific cleaner according to the manufacturer's instructions; heat the solution with the steam of the nozzle; keep the nozzle immersed in the solution for at least 5 minutes so as to allow the cleaner to rise up into the nozzle as a result the cooling effect; repeat the operation 2 or 3 times so that subsequent dispensing don't leave milk residue. 			X
<p>STEAM NOZZLE - MILK FOAMER - AUTOSTEAMER Keep the nozzle clean at all times using a cloth dampened in lukewarm water.</p>	X						
<p>PERFORATED DISK and CONTAINMENT RING Loosen the screw (A) and remove the perforated disk (B) and containment ring (C) from the delivery group. Wash with hot water.</p> 		X		<p>DISPENSING UNIT Carry out the washing of the groups as indicated in Chapter "Group washing" and follow the instructions below:</p> <ul style="list-style-type: none"> use the blind filter holder; pour the detergent on the solid filter and attach the filter holder; Carry out a series of dispensing until the water comes out clean; remove the filter holder from the unit and carry out at least one delivery so as to eliminate any detergent residues. 	X		
<p>BODY Clean the panels of the body with a cloth dampened in lukewarm water. Do not use abrasive detergents which may scratch the surface of the body. Remove the tray and the cup holder grille and wash with hot water. During the cleaning operations, pay attention to the edges and protruding parts</p>	X			<p>GRINDER-DOSER Clean the inside and outside of the receptacle and doser of the grinder-doser with a cloth dampened in lukewarm water.</p>		X	

19 Malfunctions and related solutions

Problem	Cause	Solution
MACHINE LACKING POWER	The machine is off.	Turn on the machine.
NO WATER IN BOILER	The water supply tap is closed.	Open the water supply tap.
TOO MUCH WATER IN BOILER	Malfunction of the electrical system or hydraulic system.	Call for Technical Assistance.
STEAM DOES NOT COME OUT OF STEAM SPOUTS AND AUTOSTEAMER	<ul style="list-style-type: none"> The nozzle sprayer is clogged. The machine is off. 	<ul style="list-style-type: none"> Clean the steam nozzle sprayer. Turn on the machine.
STEAM MIXED WITH WATER COMES OUT OF THE NOZZLES AND THE AUTOSTEAMER	Malfunction of the electrical system or hydraulic system.	Call for Technical Assistance.
NO DISPENSING	The water supply tap is closed.	Open the water supply tap.
WATER LEAKS FROM THE MACHINE	<ul style="list-style-type: none"> The pad does not drain. The drain pipe is broken or detached or the water flow is obstructed. 	<ul style="list-style-type: none"> Check the sewer drain. Check and restore the connection of the drain pipe to the pad.
COFFEE IS TOO HOT or TOO COLD	Malfunction of the electrical system or hydraulic system.	Request Technical Assistance.
COFFEE IS BEING DISPENSED TOO QUICKLY	Coffee is ground too coarsely	Adjust the grinding of the coffee.
COFFEE IS BEING DISPENSED TOO SLOWLY	Coffee is ground too finely.	Adjust the grinding of the coffee.
WET COFFEE GROUNDS	<ul style="list-style-type: none"> Dispensing group is dirty. The dispensing unit is too cold. Coffee is ground too finely. The coffee is too old. 	<ul style="list-style-type: none"> Wash the group with the blind filter. Wait for the group to heat up completely. Adjust the grinding of the coffee. Replace with fresh coffee.
THE PRESSURE GAUGE INDICATES AN UNACCEPTABLE PRESSURE	Hydraulic system failure	Call for Technical Assistance.
THERE ARE GROUNDS IN THE CUP	<ul style="list-style-type: none"> The filter holder is dirty. The filter holes are worn. The coffee is not ground evenly 	<ul style="list-style-type: none"> Clean the filter holder. Replace the filter. Adjust the grinding suitably.
THE CUP IS DIRTY WITH COFFEE SPURTS	<ul style="list-style-type: none"> Coffee is ground too coarsely The filter's edge is damaged 	<ul style="list-style-type: none"> Adjust the grinding of the coffee. Replace the filter.

Problem	Cause	Solution
<ul style="list-style-type: none"> • COFFEE DISPENSING IS NOT CONFORMANT • THE COFFEE DOSE IS NOT MET 	Coffee is ground too finely.	Adjust the grinding of the coffee.
COFFEE DELIVERY OCCURS ONLY USING THE MANUAL BUTTON	Electronic system failure.	Call for Technical Assistance.
SHUTDOWN OF THE ELECTRONIC SYSTEM	Malfunction of the electrical system or hydraulic system.	Call for Technical Assistance.
THE PUMP LEAKS WATER	Pump malfunction.	Call for Technical Assistance.
THE MOTOR STOPS SUDDENLY OR THE THERMAL PROTECTOR INTERVENES DUE TO OVERLOAD	Pump malfunction.	Call for Technical Assistance.
THE PUMP FUNCTIONS BELOW NOMINAL CAPACITY	Pump malfunction.	Call for Technical Assistance.
THE PUMP IS NOISY	Pump malfunction.	Call for Technical Assistance.

Alarm signal

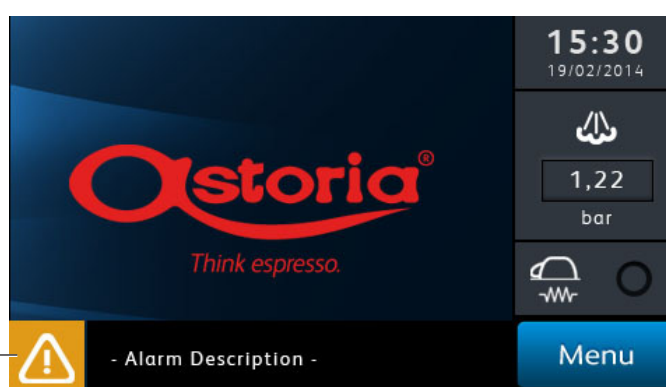

If the problem cannot be resolved, turn the machine off and call for Technical Assistance. Do not attempt any sort of repairs.